

DESCRIPTION

The PC-3CL is a completely-sealed, flush-mounted ceiling speaker made up of a high power handling, splash-proof, small full-range speaker employing a plastic film diaphragm. Its chemical-resistant grille makes the speaker ideal for use in clean rooms, hospital operation rooms, and hot and humid locations such as bath rooms and wet sauna rooms.

SPECIFICATIONS

Rated Power	3 W
Rated Impedance	100 V line: 3.3 kΩ (3 W), 10 kΩ (1 W) 70 V line: 3.3 kΩ (1.5 W), 10 kΩ (0.5 W)
Sensitivity	87 dB (1 W, 1 m)
Frequency Response	150 Hz – 20 kHz
Speaker Component	8 cm cone-type (vibration section: high molecular substance)
Operating Temperature	-20 °C to +60 °C
Chemical Resistance	Resistive to formalin solvent and iodine liquid (disinfectant)
Finish	Panel: Allory-coated ABS resin Enclosure: ABS resin Punching net: Stainless steel
Dimensions	ø139 × 104.5 (D) mm
Weight	550 g
Dimension for Fixing Holes	ø100 mm (Ceiling panel: Must be over 5 mm in thickness, equivalent to plywood in material, and strong enough to hold tapping screws.)
Accessory	Packing (Material: Silicon rubber) ...1, Paper pattern ...1, Ceiling mounting tapping screws (Material: Stainless steel) ...4

[Note] The speaker cannot be used in dry sauna rooms or locations where unit is splashed with water.

APPEARANCE

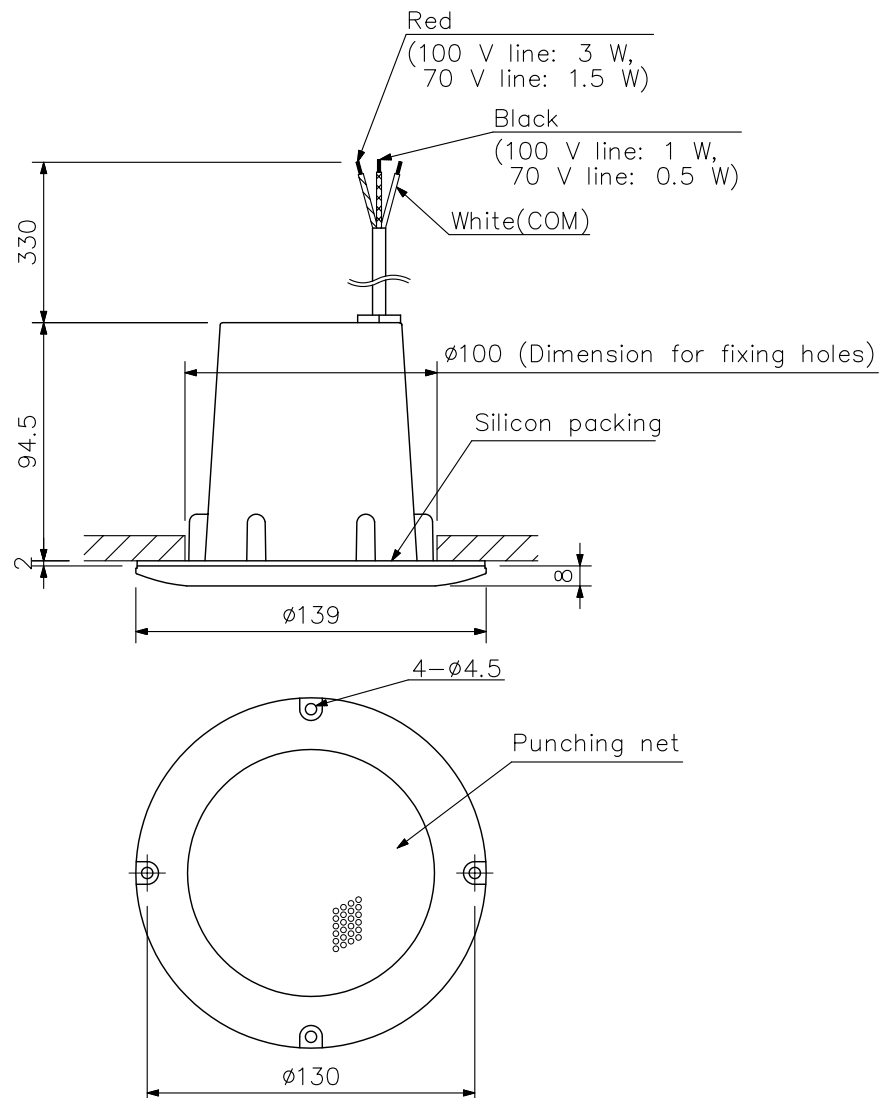

UNIT:mm SCALE:1/3